

# Safety Precautions

## Important information

This manual contains warnings and notes, which you should observe to ensure your own personal safety, as well as to protect the product and connected equipments. They are marked as follows according to the level of danger.

**Warning**  Indicates that the potential serious damage to the system may be caused if proper precautions are not taken.

1. When the system is short of voltage, the batteries should be recharged in time. Otherwise, the life span of the batteries will be influenced.

2. Please use the same brand batteries, and do not use a new battery together with an old battery at the same time.

3. Please do not charge the non-rechargeable battery.

4. Please do not pull the antenna forcefully.

**Notes**  Indicates the slight damage to the system may be caused if proper precautions are not taken.

1. Please clean the machine by dry soft cloth. Do not clean the machine with gasoline, or other chemical products.

2. Please do not touch the body with the antenna.

3. Please do not twist or knob the antenna with the microphone wire.

# Chapter 1 System Description

## 1.1 Introduction

The UHF Tour Guide System AG500 series is a portable, high- performance, wireless system composed of the AGT500 body-pack Transmitter and AGR500 body-pack Receiver. Whether at the crowded tourist attractions or at the noisy factory, the system delivers high quality sound very clearly and allows the user to move around freely at the certain distance without any influence on the quality of received sound. This system is an all-round equipment designed for language interpretation and tour group. It is widely used in group visiting activities such as touring, factory visit, training classes etc.

## 1.2 Applicable Occasions

- Factory Visit
- Tourist Attractions
- Museum
- International Meeting
- Large-scale Speech
- Exhibition
- Gymnasium
- School Meeting Room

## 1.3 Components of the Product

- AGT500 body-pack transmitter
- AGR500 body-pack receiver
- Headset microphone / Lavalier microphone
- Stereo earphone
- Portable charging case
- Transmitter/Receiver carrying case

## 1.4 Main Features

- Portable, exquisite, stylish and user-friendly streamline design.
- Adopting UHF system and 700-960MHz professional frequency with high anti-interference.
- PLL synthesized design, and higher frequency stability.
- Digital mute lock setting ensures no interference is picked.
- White backlit LCD displays operation menu and status clearly.
- Using ordinary “AA” size battery (Transmitter) or using built-in lithium-ion rechargeable battery with large capacity (Receiver).
- Displaying the battery capacity, and clearly indicating battery consumption status.
- Automatic power off when the battery is low to protect the battery life.
- Setting key lock mode allows you to avoid accidental triggering key operation.
- Advanced frequency group allows several groups to use this system simultaneously on the same occasion.
- External microphone input jack can input audio source, such as CD、MP3 to realize music sharing, and also can input the electronic tour guide recording.
- High quality and durable plastic cover with strong resistance to impact.

## Chapter2 Operating Instructions of AGR500 Receiver

### 2.1 Components` Names

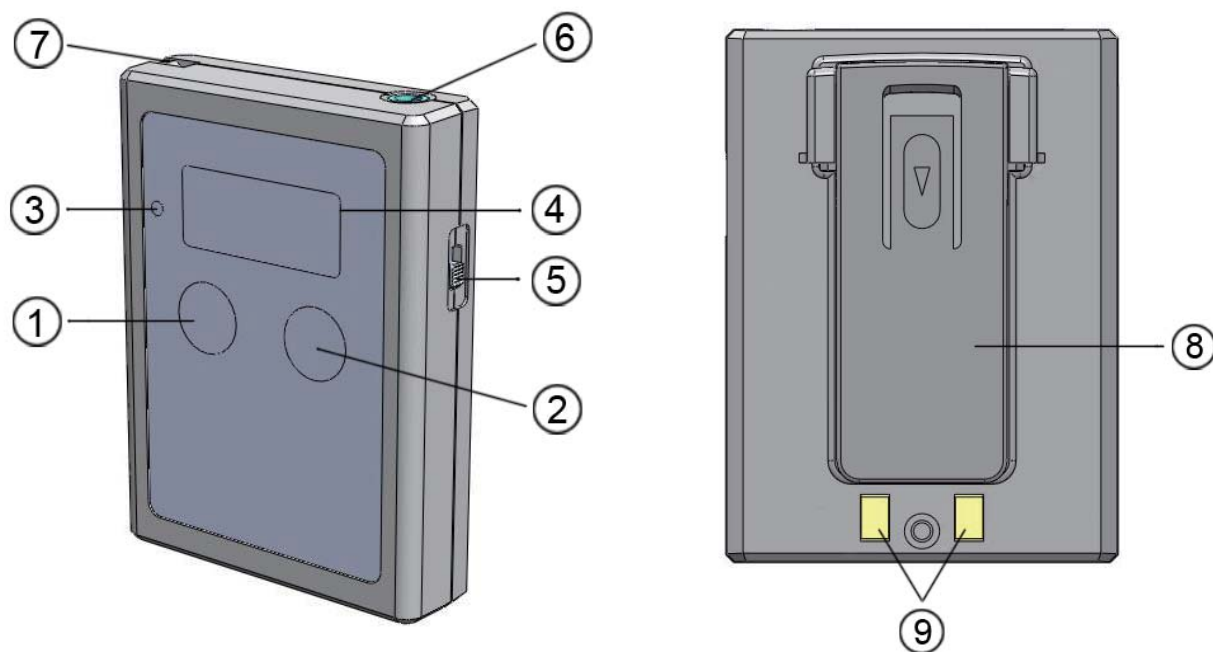

- ① ◀ / SET key
- ② ▶ / SELECT key
- ③ Red charging indicator
- ④ LCD display
- ⑤ Switch
- ⑥ Earphone/Audio output jack
- ⑦ Accessories` slot
- ⑧ Clip
- ⑨ Charging contact

## 2.2 The Description of Display Interface

The standard displays are shown as following figure 1 or figure 2 (the user-selectable frequency function is enabled), when the receiver has turned on.



figure 1



figure 2

Fig 1: CH 1      The current channel is first channel



Battery capacity indicator



Keyboard Lock mode enabled



Pilot mode enabled



Mute mode enabled

Fig 2: 854.2MHZ      User-selectable frequency



RF signal intensity indicator



Battery capacity indicator

Keyboard Lock mode, Pilot mode and Mute mode are disabled.

### NOTE:

- RF signal strength will not be displayed when the Pilot mode of the receiver is enabled.

- The Mute mode of the receiver will be enabled automatically, if the Pilot mode of transmitter is disabled when the receiver`s Pilot mode is enabled.

## **2.3 Volume Adjustment**

Press “SET” key or “SELECT” key to adjust the volume when the receiver is on the standard display (the initial value of the volume is AF 06 each time when the receiver is turned on). Press “SET” key or “SELECT” key at the first time to enter into the volume adjustment interface, then volume value decrements by one for each pressing of “SET” key (the minimum value is AF 00), and volume value increments by one for each pressing of “SELECT” key (the maximum value is AF 16). The settings will be saved and the interface will return to the standard display when no any operation of keys in 5 seconds.

## **2.4 Quick Channel / Frequency Selection**

If the channel is displayed, and press “SET” and “SELECT” keys simultaneously under the standard display to enter into channel selection interface when the Keyboard Lock mode is disabled. The channel number decrements by one for each pressing of “SET” key, and it increments by one for each pressing of “SELECT” key. The settings will be saved and the interface will return to the standard display when no any operation of keys in 5 seconds.

Press “SET” and “SELECT” keys simultaneously when the user-selectable frequency setting is enabled to enter into the interface of user-defined frequency selection. The frequency range is from 854.0MHz to 865.0MHz. The frequency value decrements by 0.1MHz for each pressing of “SET” key, and it increments by 0.1MHz for each pressing of “SELECT” key. If press and hold “SET” key or “SELECT” key, frequency value will be quick reduced or increased continuously. The settings will be saved and the interface will return to the standard display when no any operation of keys in 5 seconds.

## **2.5 Receiver`s Function Setting**

Press and hold “SET” key and turn on the receiver simultaneously, after 3 seconds or so, the receiver will enter into the operation menu. There are 4 options: “CHAN”, “MHZ”, “**PILOT**” and “”. Press “SELECT” key to switch to different option. Press “SET” key to enter into the setting interface of the selected option. The new set function will be enabled after turn on the receiver again.

### **2.5.1 Channel Setting**

When the receiver enters into the setting interface of the “CHAN” options, if the current channel is displayed, press “SELECT” key can switch the channel at this time. Press “SET” key to save the current settings and return to menu. The current operation will be invalid and return to operation menu when no any operation of keys in 5 seconds.

### **2.5.2 User-selectable Frequency Setting**

When the receiver enters into the setting interface of “MHZ” option, if the screen displays “OFF”, the user-selectable frequency function is disabled; if the screen displays “ON”, which indicates the user-selectable frequency function is enabled. Press “SELECT” key to shift between “ON” and “OFF”, and press “SET” key to save the current settings and return to the operation menu. The current operation will be invalid and return to operation menu when no any operation of keys in 5 seconds. When the receiver has been set the channel, the user-selectable frequency function will be disabled automatically.

### **2.5.3 Pilot Mode Setting**

When the receiver enters into the setting interface of “**PILOT**” option, if the screen displays “OFF”, the pilot mode is disabled; if the screen displays “ON”, which indicates the pilot mode is enabled. Press “SELECT” key to shift between “ON” and “OFF”, and press “SET” key to save the current settings and return to the operation menu. The current operation will be invalid and return to operation menu when no any operation of keys in 5 seconds.

#### **Note :**

The transmitter` s pilot mode must have been enabled before enabling the receiver` s pilot mode.

### **2.5.4 Lock Mode Setting**

When the receiver enters into the setting interface of “ ” option, if the screen displays “OFF”, the lock mode is disabled; if the screen displays “ON”, which indicates the lock mode is enabled. Press “SELECT” key to shift between “ON” and “OFF”, and press “SET” key to save the current settings and return to the operation menu. The current operation will be invalid and return to operation menu when no any operation of keys in 5 seconds.

#### **NOTE :**

Press and hold “SELECT” key and turn on the receiver at the same time to check the frequency value of set channel. Press “SELECT” key to choose channel, and press and hold “SET” key to display the frequency value of the current channel.



# Chapter3 Operating Instructions of AGT500 Transmitter

## 3.1 Components` Names

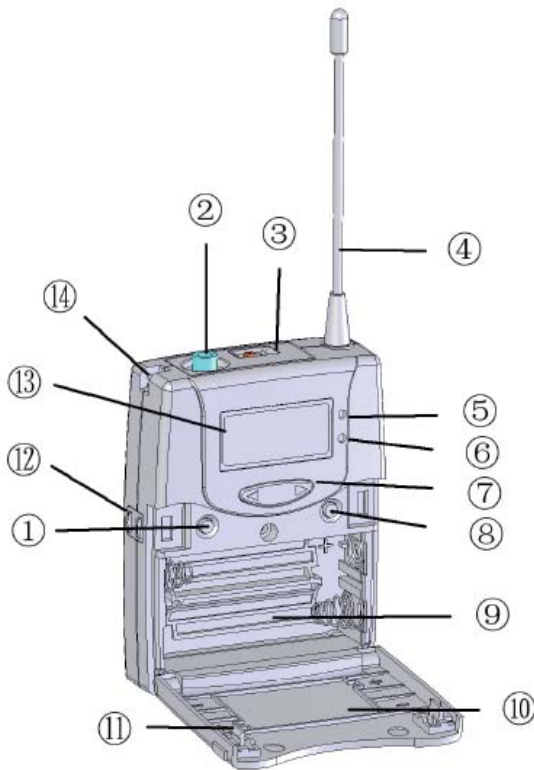

- ① ESC key
- ② Microphone/Audio input jack
- ③ MUTE key
- ④ Antenna
- ⑤ Red power status indicator (Power)
- ⑥ Green audio (voice level) modulation indicator
- ⑦ ◀ / ▶ Selection keys
- ⑧ SET Key
- ⑨ Battery compartment
- ⑩ Battery cover
- ⑪ Battery cover latch
- ⑫ Charging contact
- ⑬ Display Screen
- ⑭ Accessories` slot

## 3.2 Advance Preparation

Press two battery cover latches at the side of battery cover simultaneously to open the battery cover, and place two AA batteries in the compartment, making note of the battery polarity shown in the battery compartment, then close battery cover until it snaps shut.

Plug the headset microphone, lavalier microphone or external audio input (such as MP3 player etc.) to the microphone/audio input jack.

## 3.3 Power On/ Off

Press and hold “ESC(ON/OFF)” for almost 1 second when the power is off, then the backlit lamp of LCD turns on and appears the standard display; the red power status indicator ⑤ turns on and transmitter is enabled at the same time.

Press and hold “ESC(ON/OFF)” for 3 seconds or so when the screen is in standard display, then the screen appears “OFF”; the backlit lamp of LCD turns off and the transmitter is disabled.





## 3.4 Mute Mode Setting

Slide the mute switch to the “MUTE”. When the display shows“ **MUTE** ”, the mute mode is enabled. At this time, the microphone audio input is off and the transmitter can not receive any audio information.

### 3.5 The Description of Display Interface

The standard display is shown as follow when the transmitter has been turned on.



- |   |                                      |
|---|--------------------------------------|
| CH1   | The current channel is first channel |
|    | FM modulation indicator              |
|  | Battery capacity indicator           |
|  | Keyboard Lock mode enabled           |
|  | Pilot mode enabled                   |
|  | Mute mode enabled                    |

### 3.6 Transmitter`s Function Setting

Press “SET” key to enter into the operation menu when the screen is in standard display. Shown as follow:

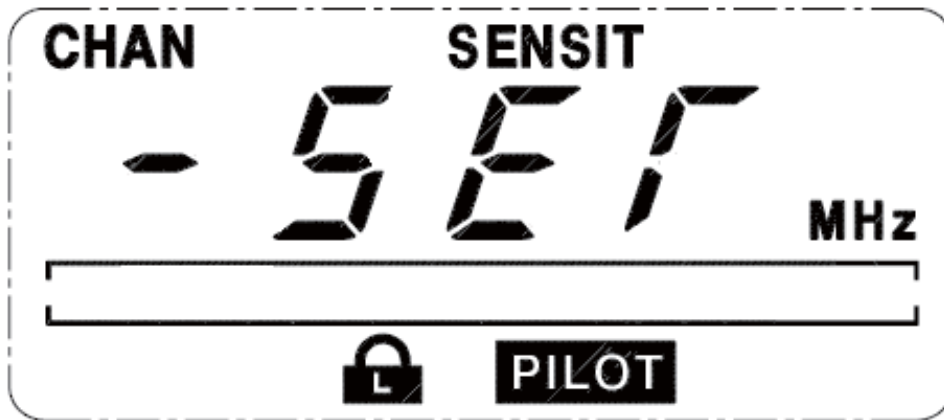

- CHAN      Channel setting menu
- SENSIT    Sensitivity setting menu
- MHz        User-selectable frequency setting menu
- PILOT**    Pilot setting menu
-       Keyboard lock setting menu

#### 3.6.1 Channel setting

During the screen in operation menu, press ◀ / ▶ key to make the “CHAN” indicator blink, then press “SET” key to enter into the channel setting mode.

The desired channel can be selected by pressing ◀ / ▶ key. Press “SET” key to save the current selected channel and return to the operation menu or press “ESC” key to give up the present selection and return to the operation menu.

### 3.6.2 Sensitivity Setting

During the screen in operation menu, press ◀ / ▶ key to make the “SENSIT” indicator blink, then press “SET” key to enter the sensitivity setting mode.

If the preset sensitivity is too high and the input signal to the transmitter is too strong, the modulated audio will be caused to be so strong that the FM modulation indicator flashes with full segments and the green audio (voice level) modulation indicator ⑥ will turn on. The sensitivity can be lowered properly by pressing ◀ key at this time. If the preset sensitivity is too low, the modulated audio is so weak that the surrounding noise will be picked up and the audio input quality will be affected. At this time, you may press ▶ key to enhance the sensitivity properly. At last, press “SET” key to save the current selected sensitivity and return to the operation menu or press “ESC” key to give up the present selection and return to the operation menu.

When the normal speech voice or audio source input is ideally set, the FM modulation indicator will flash with 3 to 5 segments, and the green audio (voice level) modulation indicator will turn off.

#### **Note:**

In order to gain the optimal received quality, please set the transmitter's sensitivity according to the real needs!! The sensitivity setting reference is shown as followings:

External audio source input    sensitivity is set at -30 or -20 dBm

Microphone input    sensitivity is set at -10 or 0 dBm

### 3.6.3 User-selectable Frequency Setting

During the screen in operation menu, press ◀ / ▶ key to make the “MHz” indicator blink, then press “SET” key to enter into the user-selectable frequency setting mode. The frequency range is from 854.0MHz to 865.0MHz, and the frequency value decrements by 0.1MHz for each pressing of ◀ key, and increments by 0.1MHz for each pressing of ▶ key. If press and hold ◀ or ▶ key, the frequency will decrease or increase continuously. Press “SET” key to save the current selected frequency and return to the operation menu or press “ESC” key to give up the present operation and return to the operation menu.

If the screen returns to the standard display after the user-selectable frequency mode is enabled, the LCD display will not show the work bank and channel, but the user-selected frequency value will be shown. If the user set the channel or work bank after having enabled user-selectable frequency mode, the user-selectable frequency mode will be disabled automatically.

### 3.6.4 Lock Mode Setting

During the screen in operation menu, press ◀ / ▶ key to make the “” indicator blink, then press “SET” key to enter into the lock mode. If the display shows “ON”, it indicates the transmitter is in lock mode now; if the display shows “OFF”, it indicates that the lock mode is disabled. Pressing ◀ / ▶ key can switch between “ON” and “OFF”. Press “SET” key to save the current settings and return to the operation menu; and press “ESC” key to give up the present operation and return to the operation menu.

When the screen shows “” icon, the ◀ / ▶ becomes invalid, but the “ESC” key and “SET” key can still be used effectively.

### 3.6.5 Pilot Mode Setting

During the screen in operation menu, press ◀ / ▶ key to make the “**PILOT**” indicator blink, then press “SET” key to enter into the pilot mode setting. If the display shows “OFF”, it indicates the pilot mode is disabled; if the display shows “ON”, it indicates the transmitter is in pilot mode now. Pressing ◀ / ▶ key can switch between “ON” and “OFF”. Press “SET” key to save the current settings and return to the operation menu; and press “ESC” key to give up the present operation and return to the operation menu.

#### NOTE:

- The transmitter` s pilot mode must have been enabled before enabling the receiver` s pilot mode.
- During the transmitter is in the setting status, if no key operation has occurred in 10 seconds, the screen will exit the setting mode automatically and return to the standard display.
- Press “ESC” key to return to the standard display when the transmitter is in the operation menu.
- It is unnecessary to reset when you restart the transmitter, because all settings have been saved after the transmitter is turned off.
- When the keyboard lock function is disabled, pressing any key will turn the backlit lamp on. If no key operation has occurred in 15 seconds, the backlit lamp will turn off.
- When the standard display shows the channel, pressing ◀ / ▶ keys simultaneously can display the present frequency of the current channel. If press ◀ or ▶ keys simultaneously again at this time, or no key operation has occurred in 10 seconds, the screen will return to the standard display.

## Chapter 4 Troubleshooting

<b>Problems</b>	<b>Possible reasons</b>	<b>Solutions</b>
The receiver has no power	The batteries` capacity is too low	Replace the batteries or recharge the batteries
There is no sound when the receiver is in the normal display	There is something wrong with the earphone or microphone	Change the earphone or the microphone
	The mute mode of the transmitter is enabled	Disable the mute mode of the transmitter
	The pilot mode of the receiver is enabled, while the transmitter`s is disabled	Disable the pilot mode of the receiver, or enable the pilot mode of the transmitter
	The volume of the receiver is set as the min. “AF 00”	Raise the volume
There is too much ambient noise.	The transmitter and receiver don` t share the same channel	Set the same channel to the transmitter and receiver
	The sensitivity of the transmitter is set too low	Increase the sensitivity of the transmitter properly
The audio is distorted, and the green audio modulation indicator is lit	The sensitivity of the transmitter is set too high or the input signal to the transmitter is too strong	Lower the sensitivity of the transmitter appropriately, or weaken the input signal properly
It is unable to make quick frequency/channel selection	The keyboard is locked and the “  ” icon appears on the display	Unlock the keyboard
The receiver is unable to receive the signal when using transmitters of other brands	The pilot mode of the receiver is enabled	Disable the pilot mode of the receiver



## **Chapter5 Suggestions and Maintenance**

1. When the transmitter or the receiver will not be used for a long time, please take out the batteries from the transmitter, or get the battery of the receiver full charged, and charge it again every three months to avoid the damage to the product and batteries.
2. Keep the transmitter and the receiver in the dry place and avoid the direct sunshine.
3. Eliminate or minimize obstructions between the transmitter and receiver to avoid the interference.
4. In order to gain the optimal received quality, please adjust the sensitivity of the transmitter correctly.
5. Please clean the machine by dry soft cloth. Do not clean the machine with gasoline, or other chemical products.

## Chapter6 Technical Parameters

<b>Receiver</b>		<b>Transmitter</b>	
Number of Channels	6+N	Number of Channels	6+N
Frequency Range	854MHZ — 865MHZ	Frequency Range	854MHZ — 865MHZ
Modulation	FM	Modulation	FM
Effective Range	>100M	Output Power	10mW
Frequency Response	100HZ — 12KHZ	Frequency Response	100HZ — 12KHZ
Distortion	<1%	Distortion	<1%
Power	800MAH Lithiumion rechargeable battery	Power	Two 1.5V AA batteries
Battery Life	>12 hours	Battery Life	>12 hours
Dimensions	68 * 50 * 15 mm	Dimensions	82 * 62 * 21 mm
Weight (including battery)	54 g	Weight (excluding battery)	76 g
Environmental Temperature	-20 — 60 °C	Environmental Temperature	-20 — 60 °C