

<b>Chapter</b>	<b>General Introduction</b>	<b>1</b>
1.1	Function Features	1
1.2	Front Panel	1
1.3	Rear Panel	2
1.4	Keypad Function	2
1.5	Menu	3
1.5.1	Main Menu	3
1.5.2	Mode and Parameter Setting Menu	4
1.5.3	List Operation Menu	4
1.6	Display Messages	5
1.7	Remote Programming	6
<b>Chapter</b>	<b>2 Functions and Features</b>	<b>7</b>
2.1	Local and Remote Control	7
2.2	Main Functions:	7
2.3	Basic Test Functions	7
2.3.1	Constant Current Mode	7
2.3.1.1	Current Setting Range	7
2.3.1.2	Immediate Current Level	8
2.3.1.3	Software Current Limit	8
2.3.2	Constant Voltage Mode (CV)	8
2.3.2.1	Setting Ranges	9
2.3.2.2	Immediate Voltage Level	9
2.3.3	Constant Resistance Mode (CR)	9
2.3.3.1	Setting Range	9
2.3.3.2	Immediate Resistance Level	9
2.3.4	Constant Power Mode (CP)	10
2.3.4.1	Setting Range	10
2.3.4.2	Immediate Power Level	10
2.4	List Operation	10
2.5	Input Control	10
2.5.1	Turn On/Off the Load	11
2.5.2	Minimum Input Voltage	11
2.5.3	Maximum Current	11
2.6	Measurement Function	11
2.7	Saving and Recalling	11
2.8	Protection Function	12
2.8.1	Clearing Latched Protection	12
2.8.2	Overvoltage	12
2.8.3	Overcurrent	12
2.8.4	Overpower	12
2.8.5	Overtemperature	13
2.8.6	Reverse Voltage	13
2.9	Auxiliary Functions	13
2.9.1	Knob Function	13

2.9.2 Key Sound .....	13
<b>Chapter3 Installation .....</b>	<b>14</b>
3.1 Initial Check .....	14
3.2 Environment/Installation Location .....	14
3.3 Power-On/ Self-Test .....	14
3.4 Connections on the Rear Panel .....	14
3.5 Connections on the Front Panel .....	15
3.6 Wiring .....	15
<b>Chapter 4 Local Operation .....</b>	<b>17</b>
4.1 Local Control .....	17
4.2 Main Operation on the Front Panel .....	17
4.3 Connecting to the Power Supply .....	17
4.4 Turning the Input On/Off .....	17
4.5 Basic Operation .....	17
4.5.1 CC Mode .....	18
4.5.2 CV Mode .....	18
4.5.3 CR Mode .....	19
4.5.4 CP Mode .....	20
4.6 List Operation .....	22
4.6.1 List Editing .....	22
4.6.2 Modifying, Adding and Chaining the List .....	24
4.6.3 Starting/Stopping the List .....	25
4.7 Saving and Recalling .....	25
4.8 Clear Protection Settings .....	26
4.9 Main Menu .....	27
4.9.1 Loading Default Values .....	27
4.9.2 Maximum Current .....	27
4.9.3 Knob Function .....	28
4.9.4 Key Sound .....	28
4.9.5 Communication Interface .....	28
<b>Chapter5 Remote Programming Operation .....</b>	<b>29</b>
5.1 Communication Interface .....	29
5.1.1 RS232 .....	29
5.2 Sending a Remote Command .....	29
5.3 Returning Data .....	29
5.4 Remote Programming Commands .....	30
5.4.1 Modes .....	30
5.4.2 Programmable Current Protection .....	30
5.5 CC Mode Example .....	31
5.6 CV Mode Example .....	30
5.7 CR Mode Example .....	30
<b>Specifications .....</b>	<b>31</b>
<b>Declaration .....</b>	<b>33</b>

# Chapter General Introduction

ARRAY 3715A programmable electronic load, as a new generation product of ARRAY Electronic Co., Ltd., is designed with high performance. It provides you powerful test function, user-friendly HMI, as well as RS232 interface to support SCPI and Labview. 3715A can be widely used in scientific research and production fields such as aerospace, shipbuilding, automotive electronics, solar cell, and fuel cell.

All “electronic load” and “load” in this manual refer to ARRAY 3715A Electronic Load if there is no special explanation.

## 1.1 Function Features

Main functions and features of ARRAY 3715A :

- 4 basic test functions: CC,CV, CR, and CP;
- 16 bits D/A and 12 bits A/D converters incorporated;
- The minimum operating voltage is less than 2V at the load’s full rated current. The maximum current can be achieved even though the input voltage is 0V. This is especially suitable for fuel cell, solar cell and other new energy test applications;
- Perfect protection assures high reliability in the most complicated test environments;
- Powerful sequential test function; with a minimum step time of 50mS; and a maximum step time of 99999S. Cycle time can be adjusted between 0-255 and a sequence can be chained to another one to achieve even more complex test procedures;
- A high-efficiency, intelligent cooling system can effectively reduce system temperature and enhance power density;
- Status saving function simplifies test operation;
- The combined use of knob and digital keypad makes the operation more convenient;
- Save/recall function can save multiple groups of common settings;

## 1.2 Front Panel

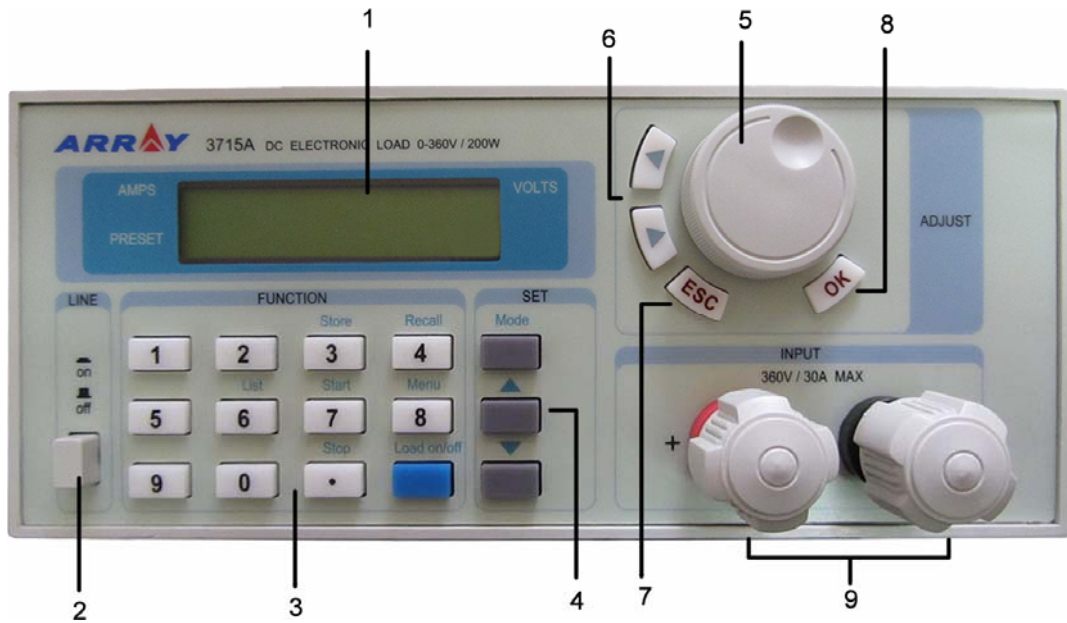

Fig. 1-1 Front Panel

- ①LCD ②Power switch ③ Number keys/ Second function keys ④Mode setting keys  
 ⑤Knob ⑥ Left/Right keys ⑦Escape key ⑧Enter key ⑨Input terminals

### 1.3 Rear Panel

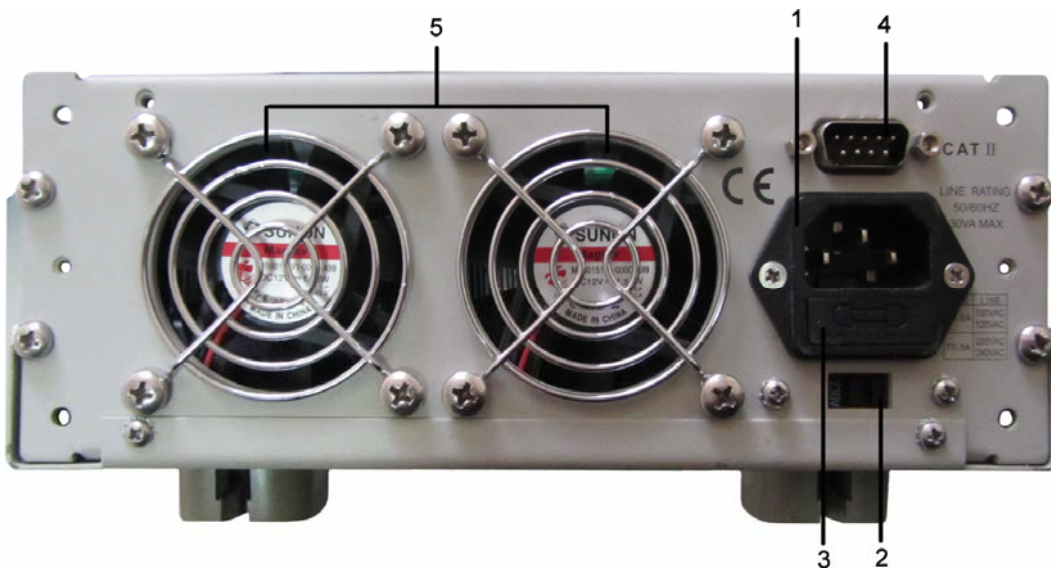

Fig1-2 Rear Panel





- ①AC input socket ②Line voltage switch ③Fuse holder ④RS232 Interface  
 ⑤ Air outlet

### 1.4 Keypad Function

There are three groups of keypads on the front panel: the Function Keys, the Number Keys,

which composite with secondary functions, and the Direction Keys. For the composite keys, the black letters in it indicate their primary function. And the secondary functions of the Number Keys are printed in blue. For example: as for Number key 4, 4 represents its primary function and “recall” its secondary function. When numbers are input, the Number keys work while the secondary function keys are valid in other modes.

List 1-1 Description for Keys

0	0
1	1
2	2
3/Store	3/Store key
4/Recall	4/ Recall key
5	5
6/List	6/List operation key
7/Start	7/List start key
8/Memu	8/Main menu key
9	9
. /Stop	Decimal point/List stop key
Load on/ off	Turn on/ off the load
MODE	Mode selection key
	Left key
	Right key
	Up key
	Down key
ESC	Escape key
OK	Enter key

## 1.5 Menu

### 1.5.1 Main Menu

Press  key to enter into main menu.

Function and Parameter	Description
Load Default Yes *No	Restore default Yes No
Max Current 30. 000A	Maximum Current Current limit
Max Power 200. 00W	Maximum Power Power Limit
Min Input Volt	Minimum Input Voltage

0.000v		Minimum Voltage
Knob *On Off		Knob Function On Off
Key Sound *On Off		Key Sound On Off
<b>RS232 interface</b>	Baudrate (k): 2.4 9.6 *19.2 38.4 57.6 115.2	Baud Rate Setting 2.4 9.6 *19.2 38.4 57.6 115.2
	Parity Check *None Even Odd	Parity Check None Even Odd
	Data Bit 8 *9	Data Bit 8 9
	Stop Bit 1 *2	Stop Bit 1 2

Note: Except knob, key sound and interface configurations, the other parameters in the main menu will not be saved when the load is turned off. If it is needed to save the parameters, please use Store command. When the load is turned on next time, the parameters saved in location 0 will be recalled automatically.

### 1.5.2 Mode and Parameter Setting Menu

Press Mode key to enter into mode and parameter setting menu, which is shown as below:



Function and Parameter	Description
MODE: CC CURR: 0.000A	Constant current mode Immediate current level
MODE: CV VOLT: 350.00V	Constant voltage mode Immediate voltage level
MODE: CR RES: 2.000 $\Omega$	Constant resistance mode Immediate resistance level
MODE: CP POWR: 0.000W	Constant power mode Immediate power level

### 1.5.3 List Operation Menu

Press List key to enter into the list operation menu, which is shown as below:

Function	Description
No.	Select list number (0-3)
Chain: Off	Sequence number to be chained with (0-3, off)
Steps: 0	Steps:(0-9)
Counts: 0	Cycle count: 0-255
Edit	Edit list

Reset	Restore default
-------	-----------------

Press  and  keys in list operation menu to select “Edit” and then press “OK” to enter into sequence data editing status, which is shown as below:

Function	Description
Step: 01.      99999s	Lis number    Time
Mode: CC      5.000A	Mode          Set value

## 1.6 Display Messages

① CC Mode:



The first line shows measured voltage and current levels. The second line shows current set level, operation mode (CC indicates constant current mode) and input status of the load: (ON, OFF).

② CV Mode:



The first line shows measured voltage and current levels. The second line shows voltage set level, operation mode (CV indicates constant voltage mode), and input status of the load: (ON, OFF).

③ CR Mode:



The first line shows measured voltage and current levels. The second line shows resistance set level, operation mode (CR indicates constant resistance mode) and input status of the load: (ON, OFF).

④ CP Mode:

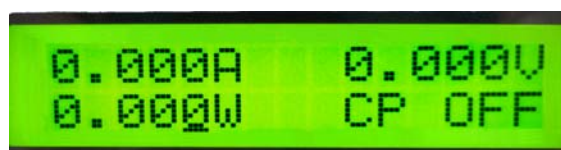

The first line shows measured voltage and current levels. The second line shows power set level, operation mode (CP indicates constant power mode, and input status of the load: (ON, OFF).

⑤ List Operation:



The first line shows measured voltage and current levels. The second line shows current set level, sequence operation mode (LCC indicates list operation in CC mode; LCV indicates list operation in CV mode; LCR indicates list operation in CR mode; LCV indicates constant voltage mode list operation; LCR indicates list operation) and input status of the load: (ON, OFF).

⑥ Protection Status

If the protection function is active, LCD will display corresponding protection status. For example: the display of reverse voltage protection status is shown as below:



Protection status includes overcurrent (OC), overvoltage (OV), overpower (OP), over temperature (OT), load protection (PT), and reverse voltage (RV).

## 1.7 Remote Programming

The commands are sent to electronic load via remote interface (RS232), and will be executed after decoding by the processor. If there is any error occurs to the command, the processor can detect the wrong command and error type, and it can maintain the status register as well.



## Chapter2 Functions and Features

The functions and features of electronic load will be described in this chapter, which helps you to know ARRAY 3715A better.

### 2.1 Local and Remote Control

ARRAY 3715A electronic load can be controlled via its keyboard and knob, or by remote controller via remote interface. If it is needed to control the load via its keyboard and knob, the load has to stay in local control status. Local control is in effect immediately after power is applied.

Details of local operation are covered in Chapter 4 “Local Operation” and fundamentals of remote programming are given in Chapter 5 “Remote Programming Operation”. Complete SCPI programming details are given in the *ARRAY 3715A Series Electronic Load SCPI Programming Guide*.

### 2.2 Main Functions:

- Constant Current Mode: CC
- Constant Voltage Mode: CV
- Constant Resistance Mode: CR
- Constant Power Mode: CP
- List Operation: LIST: List





### 2.3 Basic Test Functions

There are four basic test functions: constant current (CC), constant voltage (CV), constant resistance (CR), constant power (CP) and eight basic operating modes: CCL, CCH, CV, CRL, CRM, CRH, CPV and CPC.

The operating mode and the associated parameters can be set via front panel or remote command. The load will remain in current mode until the setting is changed.

The set value for the electronic load becomes effective immediately when the load is turned on. If the input set value exceeds the allowed range, it will be automatically limited at maximum value or minimum value.

#### 2.3.1 Constant Current Mode

In CC mode, the load will sink a constant current in accordance with the programmed value regardless of the change of input voltage (see fig.2-1). Press Mode key in basic mode to enter into mode selection and parameter setting menu. Choose CC mode with  and  keys. Input the current level via the number keys or the knob with  and  keys and then use OK key for confirmation.

##### 2.3.1.1 Current Setting Range

The current setting range for 3715A is 0-30A. And the CC mode and relevant parameters can also be set via remote command (MODE CC CURRENT <NRf+>).

	Model	3720A	3721A	3722A	3723A
Mode	CCL	0~3A	0~40A	0~2A	0~3A
	CCH	0~30A	0~40A	0~20A	0~30A

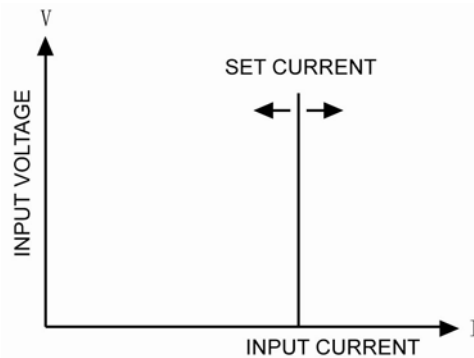

**Fig.2-1 CC Mode**

### 2.3.1.2 Immediate Current Level

The immediate current level refers to the current set value in CC mode, which can be programmed via mode selection and parameter setting menu, or via remote command (CRRRent <NRf+>). The immediate current level can also be modified directly with left/right keys (◀ ▶) and the knob.

### 2.3.1.3 Software Current Limit

The electronic load allows the user to set a current limit (the range is the same for that in CC mode) via remote commands. The load will be turned off with beeping alarms if the current limit is exceeded. Please note that the software current limit is in effect for any mode of operation.

The remote commands are:

CURRent:PROTection <NRf+>

CURRent:PROTection:DELay <NRf+>

### 2.3.2 Constant Voltage Mode (CV)

In CV mode, the load will maintain a invariable voltage based on the programmed value regardless of the change of input current ( see fig.2-2). Press Mode key in basic mode to enter into mode selection and parameter setting menu. Choose CV mode with ▲ and ▼ keys. Input the voltage value via the number keys or the knob with ◀ and ▶ keys. Use OK key for confirmation. The CV mode and parameters can also be set via remote command (MODE CV, VOLTAge <NRf+>).

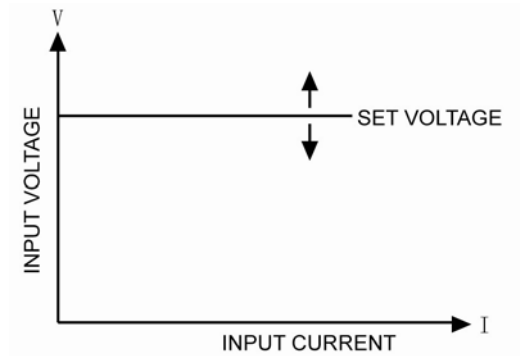

**Fig.2-2 CV Mode**

**2.3.2.1 Setting Ranges**

The voltage setting range for 3715A is 0~360V.

**2.3.2.2 Immediate Voltage Level**

The immediate voltage level refers to the voltage set value in CV mode, which can be set via mode selection and parameter setting menu, or via remote command (VOLTage <NRf+>). The immediate current level can also be modified directly with left/right keys (◀ ▶) and the knob.

**2.3.3 Constant Resistance Mode (CR)**

In CR mode, the load, being equivalent to a changless resistance, will sink a current linearly proportional to the input voltage in accordance with the programmed resistance to make  $I=U/R$  (see fig.2-3). Press Mode key in basic mode to enter into mode selection and parameter setting menu. Choose CR mode with ▲ and ▼ keys. Input the resistance value via the number keys or the knob with ◀ and ▶ keys. Use OK key for confirmation. The CR mode and parameters can also be set via remote command (MODE CRL | CRM | CRH, RESistance <NRf+>).

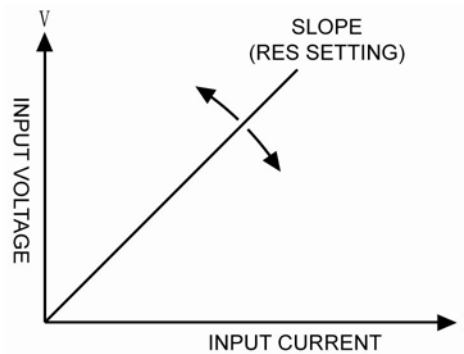

**Fig.2-3 CR Mode**

**2.3.3.1 Setting Range**

The resistance setting range for 3715A is 0-2000 Ω ..

**2.3.3.2 Immediate Resistance Level**

The immediate resistance level refers to the resistance set value in CR mode, which can be set via mode selection and parameter setting menu, or via remote command (RESistance <NRf+>). The

immediate resistance level can also be modified directly with left/right keys (◀ ▶) and the knob.

### 2.3.4 Constant Power Mode (CP)

In CP mode, the load consumes the constant power in accordance with the programmed value regardless of the output voltage of the equipment connected to the electronic load (see fig.2-4). Press Mode key to enter into mode selection and parameter setting menu. Choose CP mode with ▲ and ▼ keys. Input the power value via number keys or the knob with ◀ and ▶ keys. Use OK key for confirmation. The CP mode and parameters can also be set via remote command (MODE CPV | CPC, POWER <NRF+>).

#### 2.3.4.1 Setting Range

The setting range is 0~200W.

#### 2.3.4.2 Immediate Power Level

The immediate power level refers to the power set value in CP mode, which can be set via mode selection and parameter setting menu, or via remote command (POWER <NRF+>). The immediate resistance level can also be modified directly with left/right keys (◀ ▶) and the knob.

## 2.4 List Operation

The electronic load provides flexible list operation, which can make the load operate according to the preset sequence.

The list operation allows you to program a series of sequence steps, and the operation mode, the load values, the duration time for each step can be set. The sequence operation can be executed in the CC, CV, and CR modes. The minimum duration for each step is 500mS, and the maximum one is 99999s (around 27.78 hours). The list operation allows to be executed cyclically, and the cycle times can be set; the different list can be chained so that when one list has been executed, the another chained list will be enabled, which further perfects the capability of the list test to implement more complicated test task.

Each list can contain 10 steps at most (step: 0-9), 256 counts: (Counts: 0-255) and store 4 lists (No: 0-3).

The associated parameters of list operation can be edited and set through list operation menu or via remote command. The load provides convenient list editing function. When the user is operating input/edit sequence step, it is easy to check the previous and subsequent steps, and it is allowed to be edited immediately, which simplifies the list input operation effectively.

The set value of each step will be automatically saved when the user exits from step editing menu, and the other list parameters will be saved immediately after been edited.

The list operation also can be implemented via the remote command.

## 2.5 Input Control

### 2.5.1 Turn On/Off the Load

The input can be turned on/off by pressing **Load On/off** key, or via the remote command (INPut ON | OFF). Turning the input on/off does not affect the programmed settings.

In local control, if the input is turned on, each status of the load, such as basic modes, list operation, can not be switched directly. The load can be switched from one operation status to another only when the input is turned off.

### 2.5.2 Minimum Input Voltage

When the external input voltage is less than the minimum input voltage (Min InputVolt), the load will not be enabled even though the input has been turned on. The load will be enabled till the external input voltage reaches or exceeds the minimum input voltage (Min InputVolt),, the default value of which is 0V.

The minimum input voltage (Min InputVolt), can be set in main menu, or via the remote command (INPut:LATCh:VOLTage <NRf+>).

### 2.5.3 Maximum Current

The maximum current (Max Current) is used to limit the maximum input current. When the load reaches its set current, it will switch to the CC mode, so that it will not exceed its set current.

The maximum current can be set in main menu, or via the remote command (INPut:LIMit:CURRent <NRf+>).

## 2.6 Measurement Function

The electronic load has measurement system with high resolution. The input current level and voltage level can be measured in real time. The input power level and resistance level can be computed with the input voltage level and current level. Each measured value can be checked through LCD display or via the following remote commands:

MEASure:VOLTage?

MEASure:CURRent?

MEASure:RESistance?

MEASure:POWer?

## 2.7 Saving and Recalling

The electronic load is provided with a EEPROM memory, which can save various parameters, such as modes, input status, current value and voltage value etc.. 3715A electronic load can save 10 groups of parameters. All parameters relevant to saving and recalling operation are listed in list 2-1.

List 2-1

Function	Effect	Default
Input	Input Status	Off
Mode	Operation Mode	CC
Max Current	Maximum Current Level	30A
Max Power	Maximum Power Level	200W
Min InputVolt	Minmimum Input Voltage Level	0V

The 10 groups of parameters stored in location 0~9 can be saved and recalled by pressing **Store**

and **Recall** keys, or via the remote command (\*SAV < NRI > and \*RCL < NRI >).

The parameter saved in location 0 will be recalled automatically every time the load is turned on.

## 2.8 Protection Function

The electronic load is equipped with the following protection functions:

- Overvoltage (OV)
- Overcurrent (OC)
- Overpower (OP)
- Overtemperature (OT)
- Reverse Voltage (RV)

Once any of the above protection function is active, the input will be turned off with beeps; the detected conditions will be displayed; the load will enter into the latched protection status; the corresponding status bit in the status will be set; and will not respond to other commands except some specific operations. For example: if an overtemperature conditions has been detected, the input will be turned off with beeps, and OT will be shown in the lower right corner of the display. The load will have no response to other operations.

### 2.8.1 Clearing Latched Protection

When the load enters into the latched protection status, it will have no response to other commands. The load will return to the normal operation only when the latched protection has been reset via pressing ESC key or the remote command (INPut:PROTection:CLEAr). Of course, the condition that causes the latched protection must be removed, or it will be latched again as soon as it is reset.

### 2.8.2 Overvoltage

The overvoltage protection level is set at a predetermined voltage, which cannot be changed by the user. When the input voltage exceeds the predetermined voltage, the overvoltage protection will be enabled, and the input is turned off with OV displayed, meanwhile, the OV and VF status register bits are set, and will remain set until they are reset and overvoltage condition is removed.

### 2.8.3 Overcurrent

The electronic load allows the user to define a current protection limit. When the defined current limit is exceeded, the overcurrent protection will become effective, the load will be turned off with OC displayed, meanwhile, the OC and PS status register bits are set, and will remain set until they are reset and overcurrent condition is removed.

The current protection limit function can only be set via the remote command. It is turned on/off with the following commands:

SCPI Command	Description
CURRent:PROTection:STATe ON   OFF	Turn on/off current protection function.
CURRent:PROTection < NRf+>	Set current limit level.
CURRent:PROTection:DELay < NRf+>	Set the delay time for turning off the load.

### 2.8.4 Overpower

The electronic load is equipped with both hardware and software overpower protection functions. Once the input power exceeds the maximum rated power, the hardware power-limit circuit will be

enabled immediately to limit the input power within the allowed range. In the meantime, the load will compute the present actual power. No matter the hardware power-limit circuit is enabled, or use software to compute, the overpower protection will become active as long as the overpower time exceeds the specified limit.

When the overpower protection is enabled, the input will be turned off with OP displayed. In the meanwhile, the OP and PS status register bits are set, and will remain set until they are reset and overpower condition is removed.

### **2.8.5 Overtemperature**

If the internal temperature of the load exceeds safe limits, the overtemperature protection will be enabled; the input will be turned off with OT displayed. In the meantime, the OT and PS status register bits are set, and will remain set until they are reset and overtemperature condition is removed. You must wait until the load cools down to the normal temperature before you can reset the latched protection. The fans in the load will help to cool the load as quickly as possible.

### **2.8.6 Reverse Voltage**

When reverse voltage is applied, the reverse voltage protection will be enabled; the input will be turned off with RV displayed. In the meantime, the RV and VF status register bits are set, and will remain set until they are reset and reverse voltage is removed.

## **2.9 Auxiliary Functions**

### **2.9.1 Knob Function**

The Knob in main menu is used to enable/disable the knob function. Select On to enable the knob function, and select Off to disable.

### **2.9.2 Key Sound**

The Key Sound in main menu is used to control the key sound. Select On to activate the key sound and select Off to forbid.

## Chapter3 Installation

### 3.1 Initial Check

When you receive the load, please check it for any obvious damage that may have occurred during shipment. Keep the original packing materials in case the load has to be returned to ARRAY in the future.

Please confirm that there are no broken keys or knobs, that the cabinet and panel surfaces are free of dents and scratches, and that the display is not scratched or cracked.

### 3.2 Environment/Installation Location

The load can operate at its full power within the temperature range of 0 °C to 40 °C, and at derated power from 40 °C to 55 °C, or the overtemperature protection will be caused.

Place the load in a location with good ventilation, and keep a distance from electromagnetic interference. Do not place the load in the flammable atmosphere.

Your load must be installed in a location that allows sufficient space at the sides and rear of the load for adequate air circulation. The fans cool the load by drawing in air through the sides and exhausting it out the back.

### 3.3 Power-On/ Self-Test

A power-on self-test can inspect the basic operations of the load to assure you that the load is operational.

First, check AC power-line voltage to verify the power-line voltage selected by Line Voltage Switch on the rear panel is in accordance with the proper voltage in your local place.

Connect the power-line cord and a power-on self-test occurs automatically when you turn on the load. If there is no error is detected, the load will enter into CC mode and the load input is disabled. If the parameters were modified previously and saved in location 0, the load will recall these modified parameters automatically. After a warm-up for 30 minutes, the following test can be executed:

Connect the output terminals of a power supply with CV and CC mode to the load's input terminals with correct polarity to execute CC 5A and CV 5V operations. If the load works normally, it will draw 5A or set input voltage to 5V within the allowed tolerance.

### 3.4 Connections on the Rear Panel

The rear panel is shown as fig. 3-1, which mainly includes AC input part and communication interface part. The AC input part includes AC input socket, Fuse holder, and Line voltage switch; the interface part includes RS-232 interface.



Fig. 3-1,



AC input:

AC power-line cord must be appropriate for your local standard.

The specifications of the fuse: 250V 315mA.

Line voltage switch can switch the voltage from 110V to 220V. The selected voltage should be in accordance with the proper voltage in your local place.

Communication Interfaces:

RS-232 Interface:

The load provides a RS-232 interface, which is a standard DB9 pin connector using DTR and DSR to execute flow control. The pin assignment is shown below:

Pin	Input/Output	Description
1	-	Not used
2	Input	RXD Receive data
3	Output	TXD Transmit data
4	-	Not used
5	Common	GND Ground
6	-	Not used
7	-	Not used
8	-	Not used
9	-	Not used

The interface parameters can be set in the MENU, you can use SCPI language for programming to realize the communication with the load.

### 3.5 Connections on the Front Panel

The terminals on the front panel are input terminals (INPUT+, INPUT-). See Fig. 3-2.

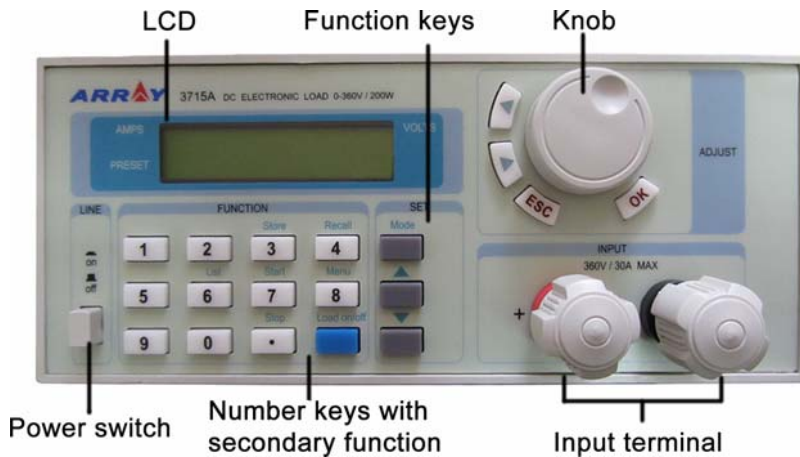

Fig.3-2

Input Connections

Input connections are made to two binding posts (INPUT+, INPUT-) on the front panel. In order to enhance the test accuracy, and reduce the test error when executing large current test, it would be better to use thicker wire.

### 3.6 Wiring

### Parallel Connections

Figure 3-4 illustrates how two or more loads can be paralleled in CC mode when higher power or larger current is needed.

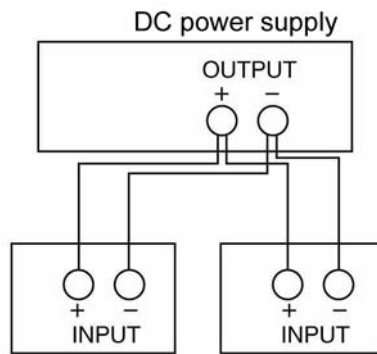

**Fig.3-3**

## Chapter 4 Local Operation

The local operation of the load has been briefly introduced in Chapter 2. In this chapter, it will be explained in details with examples.

### 4.1 Local Control

If it is needed to control the load from the front panel, the load must stay in the local control status. The load enters into local control status once it is powered on, and preset parameters saved in EEPROM location 0 will be recalled automatically.

Under remote control status, all operations are manipulated by remote controller. The electronic load will return to local control state after receiving the command (SYSTEM:LOCAL).

### 4.2 Main Operation on the Front Panel

- Connecting to the Power Supply
- Turning the Input On/Off
- CC Mode
- CV Mode
- CR Mode
- CP Mode
- List Operation
- Saving and Recalling Parameters
- Clear Protection Settings
- Error Messages
- Main Menu

### 4.3 Connecting to the Power Supply





Connect the positive pole of the power supply to the INPUT + terminal, and connect the negative pole of the power supply to the INPUT - terminal. If the input is connected reversely, the RV protection status of the load will become effective. In this case, RV will be displayed and please make the correct connections.

### 4.4 Turning the Input On/Off

Press Load On/Off key to turn on or turn off the load input.

### 4.5 Basic Operation

The operating procedures for basic tests are shown below:





1. Press Mode key to enter into mode selection and parameter setting menu.
2. Use ,  keys to select one operating mode.
3. Use Number keys, or use the knob together with ,  keys to input set value. Press ESC key to quit from mode selection and parameter setting menu.
4. Press OK key to confirm and return.

5. Press Load On/Off key to turn on the load input.

#### 4.5.1 CC Mode

Example1: Set the load to CC, current 5.12A in CV mode, and turn on the load.

The operating procedures are shown below:



Procedures	Operation Descriptions	Display
1	Press Mode key to enter into mode selection and parameter setting menu;	MODE: CV VOLT: 0.000V
2	Use  or  key to select CC;	MODE: CC CURR: 0.000A
3	Use Number keys, or use the knob together with  ,  keys to input the current value to 5.12;	MODE: CC CURR: 5.120A
4	Press OK key to confirm and exit mode selection and parameter setting menu;	0.000V 0.000A 5.120A CC OFF
5	Press Load On/Off key to turn on the load.	0.000V 0.000A 5.120A CC ON

For the above operating procedures, the corresponding SCPI commands should be:

```
MODE      CC           ; Sets the mode
CURR      5.12        ; Sets the current value
INPUT     ON          ; Turns on the load
```

#### 4.5.2 CV Mode

Example1: Set the load to CV and the voltage value to 50V in CC mode, and turn on the load.

Procedures	Operation Descriptions	Display
1	Press Mode key to enter into the mode selection and parameter setting menu;	MODE: CC CURR: 3.800A
2	Use  key to select CV mode;	MODE: CV VOLT: 0.000V
3	Use Number keys or use the knob together with  ,  keys to input the voltage value to 50;	MODE: CV VOLT: 50.000V
4	Press OK key to confirm and exit the mode selection and parameter setting menu;	0.000V 0.000A 50.000V CV OFF
5	Press Load On/Off key to turn on the load.	0.000V 0.000A 50.000V CV ON



For the above operating procedures, the corresponding SCPI commands should be:

```
MODE      CV           ; Sets the mode
VOLT      50           ; Sets the voltage value
INP       ON          ; Turns on the load
```

Example 2: Set the voltage value to 60V in CV mode.

Turn on the load, and there are two ways to set the voltage value.

Solution 1:

Procedures	Operation Descriptions	Display
1	Press Mode key to enter into the mode selection and parameter setting menu;	MODE: CV CURR: 50.00 <u>0</u> V
2	Use Number keys or use the knob together with  ,  keys to input the voltage value to 60;	MODE: CV VOLT: 60.00 <u>0</u> V
3	Press OK key to confirm and exit the mode selection and parameter setting menu;	0.000V 0.000A 60.00 <u>0</u> V CV OFF
4	Press Load On/Off key to turn on the load.	0.000V 0.000A 60.00 <u>0</u> V CV ON

Solution 2:

Procedures	Operation Descriptions	Display
1	Move the cursor to the tens with  key;	0.000V 0.000A <u>5</u> 0.000V CV ON
2	Rotate the knob to set the tens to 6; (The set value will be changed when rotating the knob. The set value will become effective at input at once when the load is turned on.)	0.000V 0.000A <u>6</u> 0.000V CV OFF
3	Press Load On/Off key to turn on the load;	0.000V 0.000A <u>6</u> 0.000V CV ON



For the above operating procedures, the corresponding SCPI commands should be:

MODE CV ; Sets the mode  
VOLT 60 ; Sets the voltage value  
INPUT ON ; Turns on the load

Note: CV will be shown in the lower right corner of the display when the load is in CV mode.

### 4.5.3 CR Mode

Example1: Set the load to CR and set the resistance value to 4.5  $\Omega$  in CV mode, and then turn on the load.

Procedures	Operation Descriptions	Display
1	Press Mode key to enter into the mode selection and parameter setting menu;	MODE: CV VOLT: 50.00 <u>0</u> V
2	Use  key to select CR mode;	MODE: CR RES : 0.02 <u>0</u> $\Omega$
3	Use Number keys or use the knob together with  ,  keys to input the resistance value to 4.5;	MODE: CR RES : 4.500 <u>0</u> $\Omega$
4	Press OK key to confirm and exit the mode selection and parameter setting menu;	0.000V 0.000A 4.500 <u>0</u> $\Omega$ CR OFF

5	Press Load On/Off key to turn on the load.	0.000V      0.000A 4.5000 $\Omega$ CR ON
---	--	---



For the above operating procedures, the corresponding SCPI commands should be:

MODE      CR                            ; Sets the mode  
RES        4.5                                    ; Sets the resistance value  
INP        ON                                    ; Turns on the load

Example 2: Set the resistance value to 4.8  $\Omega$  in CR.

Turn on the load, and there are two ways to set the resistance value.

Solution 1:

Procedures	Operation Descriptions	Display
1	Press Mode key to enter into the mode selection and parameter setting menu;	MODE: CR RES : 4.5000 $\Omega$
2	Use Number keys or use the knob together with  ,  keys to input the resistance value to 4.8;	MODE: CR RES : 4.8000 $\Omega$
3	Press OK key to confirm and exit the mode selection and parameter setting menu;	0.000V      0.000A 4.8000 $\Omega$ CR OFF
4	Press Load On/Off key to turn on the load.	0.000V      0.000A 4.8000 $\Omega$ CR ON

Solution 2:

Procedures	Operation Descriptions	Display
1	Move the cursor to the tenths with  key;	0.000V      0.000A 4.5000 $\Omega$ CR OFF
2	Rotate the knob to set the tenths to 8; (The set value will be changed when rotating the knob. The set value will become effective at input at once when the load is turned on.)	0.000V      0.000A 4.8000 $\Omega$ CR OFF
3	Press Load On/Off key to turn on the load.	0.000V      0.000A 4.8000 $\Omega$ CR ON

For the above operating procedures, the corresponding SCPI commands should be:



MODE      CR                            ; Sets the mode  
RES        4.8                                    ; Sets the resistance value  
INP        ON                                    ; Turns on the load

#### 4.5.4 CP Mode

Example1: Set the load to CP and set the power value to 100W in CR mode, and turn on the load,

The operating procedures are shown below:

Procedures	Operation Descriptions	Display
1	Press Mode key to enter into the mode selection and parameter setting menu;	MODE: CR RES : 1.8000 $\Omega$

2	Use  key to select CP mode;	MODE: CP POWR: 0.00 <u>0</u> W
3	Use Number keys or use the knob together with  ,  keys to input the power value to 100;	MODE: CP POWR: 100.00W
4	Press OK key to confirm and exit the mode selection and parameter setting menu;	0.000V      0.000A 100.0 <u>0</u> W    CP OFF
5	Press Load On/Off key to turn on the load;	0.000V      0.000A 100.0 <u>0</u> W    CP ON



For the above operating procedures, the corresponding SCPI commands should be:

MODE      CP                      ; Sets the mode  
 POW        100                            ; Sets the power value  
 INP        ON                             ; Turns on the load

Example 2: Set the power value to 200W in CP mode.

Turn on the load, and there are two ways to set the power value.

Solution 1:

Procedures	Operation Descriptions	Display
1	Press Mode key to enter into the mode selection and parameter setting menu;	MODE: CP POWR: 100.0 <u>0</u> W
2	Use Number keys or use the knob together with  ,  keys to input the power value to 200;	MODE: CP POWR: 200.00W
3	Press OK key to confirm and exit the mode selection and parameter setting menu;	0.000V      0.000A 200.0 <u>0</u> W    CP OFF
4	Press Load On/Off key to turn on the load.	0.000V      0.000A 200.0 <u>0</u> W    CP ON

Solution 2:















Procedures	Operation Descriptions	Display
1	Move the cursor to the hundredths with  key;	0.000V      0.000A <u>1</u> 00.00W    CP OFF
2	Rotate the knob to set the hundredths to 2; (The set value will be changed when rotating the knob. The set value will become effective at input at once when the load is turned on.)	0.000V      0.000A <u>2</u> 00.00W    CP OFF
3	Press Load On/Off key to turn on the load.	0.000V      0.000A <u>2</u> 00.00W    CP ON

For the above operating procedures, the corresponding SCPI commands should be:

MODE      CP                      ; Sets the mode  
 POW        200                            ; Sets the power value  
 INP        ON                             ; Turns on the load

## 4.6 List Operation

The operating procedures for enabling and disabling list operation are shown as below:













1. Press List key to enter into sequence operation menu.
2. Use Number keys or the knob to select list number (No.), and press OK key to confirm.
3. Use  key to select “Chain”; use Number keys (the “Chain” is OFF when the Number key exceeds 6) or the knob to input the set value (0-3, OFF); press  key to confirm; and save the Chain value in the EEPROM assigned by the sequence number.
4. Use  key to select “Step”; use Number keys or the knob to input the number of steps (0-9) and press OK key to confirm.
5. Use  key to select the cycle times (Counts); use Number keys or the knob together with ,  keys to input set value. Press OK key to confirm and save the cycle times in EEPROM assigned by the sequence number.
6. Use  key to select “Edit” and press OK key to enter into the editing interface for Setp 0.
7. Use Number key or the knob together with ,  keys to input the test time required and press OK key to confirm.
8. Use Mode key to select test mode (CC, CV, CR, CP); use  to move the cursor to the next line and use Number keys or the knob together with ,  keys to input test parameters; press OK key to confirm.
9. Use  to enter into the next editing operation and the procedures are the same as that illustrated in Step 7 and Step 8.
10. If some step needs modification, use ,  keys to select this step and the methods for setting this step are the same as that illustrated in Step 7 and Step 8.
11. Press ESC key to exit step editing screen, and save the sequence data in the EEPROM assigned by the sequence number.
12. Press ESC key to exit list operation menu.
13. Press Start key to enable list operation.
14. Press Stop key to disable list operation.

### 4.6.1 List Editing

Example1: Edit a new sequence. The sequence number is 0; the sequence steps: step1: CC, 1A,1S; step2: CV, 1V, 1S; step3: CR, 1Ω,1S; step4: CP, 100W, 1S; the cycle times (Count) for sequence



operation is 5; disabling the sequence chain; starting sequence operation; stopping sequence operation.

Procedures	Operation Descriptions	Display
1	Press LIST key to enter into sequence operation menu.	►No.: 0 Chain: OFF
2	Use Number keys or the knob to set the sequence number (No.) to 0, and press OK key to confirm (recall the sequence in EEPROM assigned by the sequence number).	►No.: 0 Chain: OFF
3	Use  key to enter into the next interface.	►Steps.: 0 Counts: 0
4	Use Number keys or the knob together with  ,  keys to input the steps to 4 and press OK key to confirm.	►Steps.: 4 Counts: 0
5	Use  key to down the cursor, and Number keys or the knob together with  ,  keys to input the cycle times (Count) to 5 and press OK key to confirm.	Steps.: 4 ►Counts: 5
6	Use  key to enter into the next interface.	►Edit: Reset
7	Press OK to enter into step editing screen.	Step: 0 0.000S Mode:CC 0.000A
8	Use Number keys or the knob together with  ,  keys to input the time to 1 and press OK key to confirm.	Step: 0 1.000S Mode: CC 0.000A
9	Use  to down the cursor and Number keys or the knob together with  ,  keys to input the current level to 1 and press OK key to confirm.	Step: 0 1.000S Mode: CC 1.000A
10	Use  key to enter into the next interface.	Step: 1 0.000S Mode: CC 0.000A
11	Set the other three steps according Step 8 to Step 10 operations.	Step: 1 1.000S Mode: CV 1.000V
12	Press ESC key to exit list operation menu.	
13	Press Start key to enable list operation.	
14	Press Stop key to disable list operation.	



















For the above operating procedures, the corresponding SCPI commands should be:



LIST:NUME 0 ; Recalls the number 0 sequence  
 LIST:MEMO Test Power ; Sequence memo is "Test Power"  
 LIST:ADD CC,1A,1S  
 LIST:ADD CV,1V,1S  
 LIST:ADD CR,1 Ω,1S

LIST:ADD CP,200W,1S ; The above 5 commands are sequence steps  
 LIST:COUNT 5 ; Cycle times for this sequence  
 LIST:CHA OFF ; Disables sequences chained by this sequence.  
 LIST ON ; Activates sequence operation  
 LIST OFF ; Stops sequence operation

#### 4.6.2 Modifying, Adding and Chaining the List

Example1: Based on the example1 in 4.6.1 section, the step1 is to modify the time to 2s, and the Step 2 is revised as CR, 1Ω, 10S. Add “CC, 5A, 2S” to the last step. The sequence is chained to itself to realize the continuous execution.

Steps	Operation Descriptions	Display
Step1	Press List key to enter into sequence operation menu.	►No.: 0 Chain: OFF
Step2	Use  key to down the cursor and Number keys or the knob together with  ,  keys to input 0 and press OK key to confirm.	No.: 0 ►Chain: 0
Step3	Use  key to enter into the next interface.	►Steps.: 4 Counts: 5
Step4	Use Number keys or the knob together with  ,  keys to change Step to 5 and press OK key to confirm.	►Steps.: 5 Counts: 5
Step5	Use  key to enter into the next interface and then press OK key to enter into editing screen.	►Edit: Reset
Step6	Use Number keys or the knob together with  ,  keys to input the time to 2 and press OK key to confirm.	Step: 0 2.000S Mode: CC 1.000A
Step7	Use  key to enter into the editing interface of Step 1.	Step: 1 1.000S Mode: CV 1.000V
Step8	Use Number keys or the knob together with  ,  keys to input the time to 10 and press OK key to confirm.	Step: 1 10.000S Mode: CV 1.000V
Step9	Use  to down the cursor. Press Mode key to change CV to CR. Use Number keys or the knob together with  ,  keys to input the resistance value to 5. Press OK key to confirm	Step: 1 10.000S Mode: CR 5.000Ω
Step10	Use  key to select the step 5.	Step: 4 0.000S Mode: CC 0.000Ω
Step11	Use Number keys or the knob together with  ,  keys to input the time to 2 and press OK key to confirm.	Step: 4 2.000S Mode: CC 0.000A

Step12	Use  to down the cursor, and Number keys or the knob together with  ,  keys to input the current value to 5. Press OK key to confirm	Step: 4 2.000S Mode: CC 5.000A
Step13	Press ESC key to exit list operation menu.	
Step14	Press Start key to enable list operation.	
Step15	Press Stop key to disable list operation.	

For the above operating procedures, the corresponding SCPI commands should be:

LIST:NUMB 0 ; Recalls the number 0 sequence  
 LIST:EDIT 1,CC,1A,2S ; Modifies the time for the first step.  
 LIST:EDIT 2,CR, 1Ω,10S ; Modifies the mode and time for the second step  
 LIST:ADD CC,5A,2S ; Adds “CC, 5A, 2S” to the last step.  
 LIST:CHA 0 ; Indicates the sequence is chained to itself  
 LSIT:SAVE ; Saves lists  
 LIST ON ; Activates sequence operation  
 LIST OFF ; Stops sequence operation.

### 4.6.3 Starting/Stopping the List

Example1: Start the No.0 sequence, and stop the active sequence operation.

Steps	Operation Descriptions	Display
Step1	Press LIST keys to enter into sequence operation menu.	►No.: 0 Chain: OFF
Step2	Use Number keys or knob to set the sequence number (No.) to 0, and press OK key to confirm (recall the sequence in EEPROM assigned by the sequence number).	►No.: 0 Chain: OFF
Step3	Press ESC key to exit list operation menu.	0.000V 0.000A 0.000A CC OFF
Step4	Press Start key to enable list operation.	0.000V 0.0000A 1.0000A LCCL ON
Step5	Press Stop key to disable list operation.	0.000V 0.000A 0.000A CCH OFF

For the above steps, the corresponding SCPI commands should be:

LIST:NUMB 0 ; Recalls the number 0 sequence  
 LIST ON ; Starts sequence operation  
 LIST OFF ; Stops sequence operation

### 4.7 Saving and Recalling

The operating procedures for saving and recalling operation are shown below:

1. Press Store key to enter into the saving menu, or press Recall key to enter into the recalling menu.
2. Press Number keys or the knob to select saving or recalling position.

3. Press OK key to confirm and exit the saving or recalling menu. If the saving is selected, the values of List2-1 parameters will be saved in the specified location in EEPROM; if the recalling is selected, the values of List2-1 parameters should be the values saved in specified location in EEPROM.

Example1: Set the mode to CC; set the current value to 2A; turn on the load; save the settings in the EEPROM assigned by location 0; the next time the load is turned on, these settings will become the power-on settings.

Procedures	Operation Descriptions	Display
1	Set the mode to CC; set the current value to 2A; turn on the load (please refer to 4.5.1 section for the detailed operations).	0.000V 0.000A 2.000 <u>0</u> A CC ON
2	Press Store key to enter into the saving menu.	Save File No. <u>1</u>
3	Press Number keys or the knob to select the location 0 for saving.	Save File No. <u>0</u>
4	Press OK key to confirm and exit the saving menu.	0.000V 0.000A 2.0000A CC ON

For the above operating procedures, the corresponding SCPI commands should be:

```

MODE      CC      ; Sets the load to CC status
CURR      2       ; Sets the current value to 2A
INP       ON      ; Turns on the load
*SAV      0       ; Saves the present settings in the EEPROM assigned by location 0

```

Example2: Based on the above example, set the mode to CV; set the voltage value to 40V; turn off the load; recall the values saved in the EEPROM assigned by location 0. The detailed operations are shown below:

Procedures	Operation Descriptions	Display
1	Set the mode to CV; set the voltage value to 40V; turn off the load (please refer to 4.5.2 section for detailed operations).	0.000V 0.000A 40.00 <u>0</u> V CV OFF
2	Press Recall key to enter into the recalling menu.	Recall File: No. <u>0</u>
3	Press Number keys or the knob to select the recalled location 0.	Recall File: No. <u>0</u>
4	Press OK key to confirm and return.	0.000V 0.000A 2.0000A CC ON

For the above operating procedures, the corresponding SCPI commands should be:

```

MODE      CV      ; Sets the CV mode
VOLT      40      ; Sets the voltage value to 40V
INP       OFF     ; Turns off the load
*RCL      0       ; Recalls the values saved in location 0 in EEPROM

```

#### 4.8 Clear Protection Settings

The operating procedures for clear protection settings are shown below:

1. Eliminate the reason that causes the protection status.
2. Press ESC key.

Example1: Clear RV protection of the load. The detailed operations are shown below:







Procedures	Operation Descriptions	Display
1	Connect the power supply to the load again.	0.000V 0.0000A 2.000 <u>0</u> A RV OFF
2	Press ESC keys.	0.000V 0.0000A 2.000 <u>0</u> A CC OFF

For the above operating procedures, the corresponding SCPI command should be:

INP:PROT:ESC ; Clears the protection status

## 4.9 Main Menu

The operating procedures for the main menu are shown below:

1. Press Menu key to enter into the main menu.
2. Use ,  keys to select the menu item.
3. Use the knob or ,  keys to select the parameter; or use Number keys or the knob together with ,  keys to input set value. Press ESC key to exit parameter modification or exit the main menu.
4. Press OK key to confirm.
5. Press ESC key to exit the main menu.



### 4.9.1 Loading Default Values

Example: Load the default values. The detailed operations are shown below:

Procedures	Operation Descriptions	Display
1	Press Menu key to enter into the main menu.	Load Default: Yes *No
2	Use the knob or  key to select the parameter “Yes”. Press OK key to confirm.	Load Default: *Yes No
3	Press ESC key to exit the main menu.	

### 4.9.2 Maximum Current

Example: Set the maximum current and turn on the load. This example illustrates how to enable or disable the load input automatically to simplify test operation. The detailed operations are shown below:

Procedures	Operation Descriptions	Display
1	Press Menu key to enter into the main menu.	Load Default: Yes *No
2	Use  key to select the menu item “Max Current”.	Max Current: 30. 00 <u>0</u> A
3	Use Number keys or the knob together with  ,  key to input the maximum current to 10 and press OK key to confirm.	Max Current: 10.00 <u>0</u> A

4	Press ESC key to exit the main menu.	0.000V 0.000A 0.00 <u>0</u> A CC OFF
5	Press Load On/off key to turn on the load.	0.000V 0.000A 0.00 <u>0</u> A CC ON



For the above operating procedures, the corresponding SCPI commands should be:

INP:MAX:CURR 10A ; Sets the maximum current value to 10A

INP ON ; Turns on the load



### 4.9.3 Knob Function

Example: Enable the knob function.

Procedures	Operation Descriptions	Display
1	Press Menu key to enter into the main menu.	Load Default: Yes *No
2	Use  key to select the menu item “Knob”; use the knob or  key to select the parameter “On”. Press OK key to confirm.	Knob: *On Off
3	Press ESC key to exit the main menu.	0.000V 0.000A 0.00 <u>0</u> A CC OFF



### 4.9.4 Key Sound







Example: Enable the key sound.

Procedures	Operation Descriptions	Display
1	Press Menu key to enter into the main menu.	Load Default: Yes *No
2	Use  key to select the menu item “Key Sound”; use the knob or  key to select the parameter “On”. Press OK key to confirm.	Key Sound: *On Off
3	Press ESC key to exit the main menu.	0.000V 0.000A 0.00 <u>0</u> A CC OFF

### 4.9.5 Communication Interface

Example1: Select RS232 interface; set the baut rate to 9600; set parity check to None; set data bit to 8; set stop bit to 2; enable the flow control.

Steps	Operation Descriptions	Display
Step1	Press Menu key to enter into the main menu.	Load Default: Yes *No
Step2	Use  key to select the menu item “Baud Rate (K)”; use the knob or  ,  keys to select the parameter “9.6”. Press OK key to confirm.	Baudrate (K): 2.4 *9.6

Step3	Use  key to select the menu item “Parity Check”; use the knob or  key to select the parameter “None”. Press OK key to confirm.	Parity Check: *None Even Odd
Step4	Use  key to select the menu item “Data Bit”; use the knob or  key to select the parameter “8”. Press OK key to confirm.	Data Bit: *8 9
Step5	Use  key to select the menu item “Stop Bit”; use the knob or  key to select the parameter “2”. Press OK key to confirm.	Stop Bit: 1 *2
Step5	Press ESC key to exit the main menu.	0.000V 0.000A 0.000A CC OFF

## Chapter5 Remote Programming Operation

ARRAY 3715A Electronic Load supports both local operation and remote control. The previous chapter has introduced how to use the front panel keys and knob to operate the load. This chapter will introduce you to how to program the load from the remote controller. The similarities between local and remote programming will become apparent as you read this chapter.

The intent of this chapter is to help users quickly become familiar with remote programming operations. Programming examples given in this chapter are the SCPI commands in their simplest form. Please refer to the “ARRAY 372X Series Electronic Load SCPI Programming Guide” for detailed introduction of all SCPI commands.

### 5.1 Communication Interface

#### 5.1.1 RS232

RS232 interface is standard. Use the cable shipped with the load to connect the load to a computer correctly. Select RS232 interface in the MENU, and set the baud rate, parity, data bit and stop bit to be used. Set the same parameters in the software on the computer, and input the right SCPI command to operate the load.

### 5.2 Sending a Remote Command

You can use the computer to set operation mode and operation parameters remotely for the load.

### 5.3 Returning Data

The load can return the values of parameter settings, input voltage and current, as well as input power to computer. It can also return information relating to the internal operation and module identification. For example: the query “MEAS:CURR?” asks the load to return the actual input current at the Input binding posts. Please refer to “ARRAY 372X Series Electronic Load SCPI Programming Guide” for detailed information on using queries. The load stores the response to the query in an output buffer which will hold the information until it is read by the computer or is

replaced with new information.

#### **5.4 Remote Programming Commands**

The SCPI commands have many optional key words for the programmer. Getting familiar with those key words will help you to know the programming better. Most of the commands have a query syntax which allows the present parameter settings to be returned to the controller. Please refer to “ARRAY 372X Series Electronic Load SCPI Programming Guide” for details. The load’s major functions can be programmed with a relatively few number of these commands. The following points are important to remember when you are remotely programming CC, CR, CV, and CP values.

##### **5.4.1 Modes**

The CC, CR, CV, and CP values can be programmed whether or not the associated mode is active. If the input is turned on, all of the applicable values will take effect at the input when the associated mode is selected.

##### **5.4.2 Programmable Current Protection**

When programmable current protection is enabled, and the programmed current limit and time delay are exceeded, the load’s input will be turned off.

#### **5.5 CC Mode Example**

This example sets the current level to 0.5A, and then reads back the actual current value.

```
1 "INP OFF"           ; Turns off the load` s input
2 "MODE CC"           ; Selects the CC mode
3 "CURR 0.5"          ; Sets current level to 0.5A
4 "INP ON"            ; Turns on the load` s input
5 "MEAS:CURR?"        ; Measures the actual input current
```

#### **5.6 CV Mode Example**

This example presets the trigger voltage to 5V, and selects the external trigger source.

```
1 "INP OFF"           ; Turns off the load` s input
2 "MODE CV"           ; Selects the CV mode
3 "VOLT:TRIG 5"       ; Presets the trigger voltage to 5V
4 "TRIG:SOUR EXT"     ; Selects the external input as the trigger source
5 "INP ON"            ; Turns on the load` s input
```

In this example, when the external trigger signal is received, the input voltage will be set to 5V.

#### **5.7 CR Mode Example**

This example sets the current protection limit to 3A, sets the time delay to 10s, programs the resistance level to 10  $\Omega$ , and reads back the computed power.

```
1. "INP OFF"           ; Turns off the load` s input
2. "MODE CR"           ; Selects the CR mode
3. "CURR:PROT 3"       ; Sets the current protection limit to 3A,
4. "CURR:PROT:DEL 10"  ; Set 10 seconds of time delay
5. "CURR:PROT:STAT ON" ; Activates the current protection
```



6. "RES 10" ; Sets resistance level to 10  $\Omega$   
 7. "INP ON" ; Turns on the load's input  
 8. "MEAS:POW?" ; Measures the input power level

## Specifications

<b>Model</b>	3715A
Current Voltage Power*1	0~30A 0~360V 250W at 40°C
Minimum Operation Voltage @ Full Scale Current	2V
Current Range Resolution (Accuracy)	1 mA (0~3A) $\pm 0.2\% \pm 5\text{mA}$ 10 mA (0~30A) $\pm 0.2\% \pm 30\text{mA}$
Voltage Range Resolution(Accuracy)	0~360V 1 mV (0~3.6V) $\pm 0.2\% \pm 3\text{mV}$ 10mV (0~36V) $\pm 0.2\% \pm 30\text{mV}$ 100mV (0~360V) $\pm 0.2\% \pm 300\text{mV}$
Resistance Range Resolution (Accuracy)	0~2000 $\Omega$ 0.001 $\Omega$ 0.3%+0.002 $\Omega$
Power Range Resolution @P<100W @P≥100W Accuracy	0~200W 1mW 10mW 0.2%+600mW
Step Time Resolution Accuracy	500ms~99999s 500ms 0.2%+500ms
Step Number	1~50
Cycle	1~255
Store Capacity	4 lists
<b>Protection Features</b>	OV, OC, OT, OP, RV
Current(rms/p-p) Voltage(rms)	3mA/30mA 5mV
Temperature Relative Humidity	0~40° C ≤85%
<b>Remote Interface</b> *6	RS232
<b>Programming Language</b>	SCPI

Voltage	AC110V or AC220V±15%
Frequency	48 to 63Hz
<b>Net Weight</b>	5 kg

\* Maximum continuous power available is derated linearly from 100% of maximum at 40°C, to 75% of maximum at 50 °C.

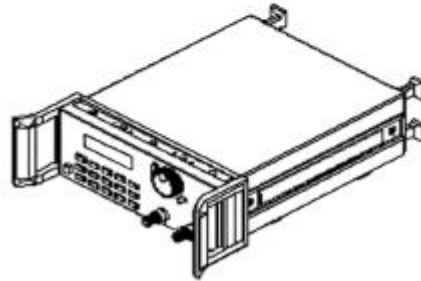
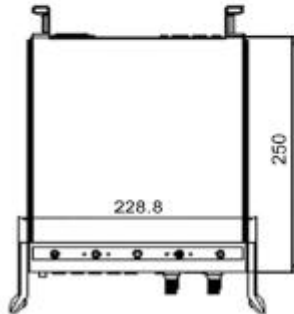
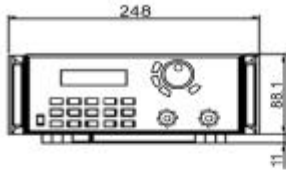

## Declaration

The name or concentration of toxic or hazardous substances or elements in electronic information products:

Accessory Name	Hazardous Substances or Elements					
	Lead (Pb)	Mercury (Hg)	Cadmium (Cd)	Hexavalent Chromium (Cr (VI))	Polybrominated Biphenyl (PBB)	Polybrominated Diphenyl Ethers (PBDE)
<b>Casing</b>	○	○	○	○	○	○
<b>* Circuit Board Assembly</b>	×	○	○	○	○	○
<b>Power Cord</b>	×	○	○	○	○	○
<b>CD, Print and Package</b>	○	○	○	○	○	○

\*: Circuit board assembly includes the printed circuit board and its components, such as the resistance, capacitance, integrate circuit and connector.

○ indicates that the concentration of the hazardous substance in all homogeneous materials in the parts is below the relevant threshold of the SJ/T 11363-2006 standard.

× indicates that the concentration of the hazardous substance of at least one of all homogeneous materials in the parts is above the relevant threshold of the SJ/T 11363-2006 standard, resulting from the lack of mature technique to improve the situation in this industry.

**Notice:** Some accessories listed in the table may not go with your products. The accessories in your packing box shall prevail.

The Environment-friendly Use Period, 10 years for products under normal application, starts from the manufacturing date. And for parts the production date of that are hard to be confirmed, the Environment-friendly Use Period dates from the manufacturing date of the complete machine. Beyond the period, please make a good classification of recoverable and unrecoverable materials.